

WARD INSTALLATION

Sleeve

Sleeve Installation Instructions FOR USE WITH ALL SERIES FIRE DAMPERS

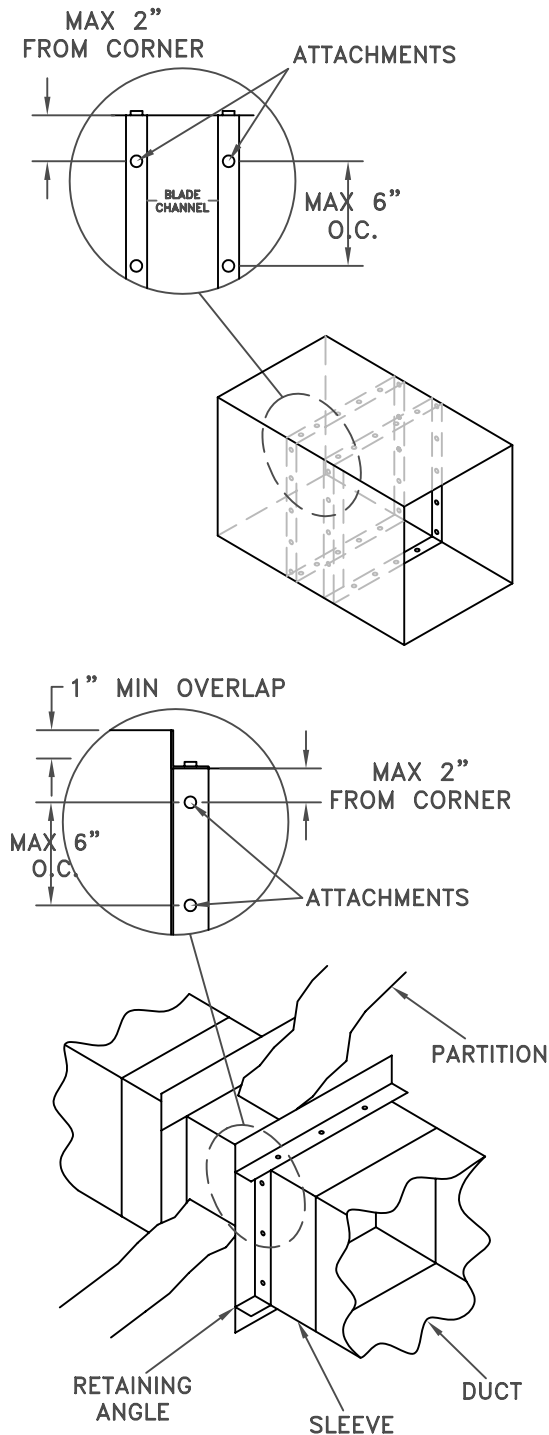

1. The installation of the damper and sleeve, and all duct connections shall conform to UL555, NFPA 90A and the SMACNA Fire, Smoke and Radiation Damper Installation Guide.
2. Attach dampers to sleeves as shown. All four sides of the damper must be attached to the sleeve with attachments on each side of the blade channel. Attachments must not enter the blade channel or interfere with damper operation. Dampers without attachment flanges must be welded to the sleeve. Attachments must be spaced a maximum of 6" on center and a maximum of 2" from corners. **Refer to "Fire Damper Installation" for more information.**
3. Fire damper and sleeve assemblies must be installed using retaining angles on each side of the partition. Mount the angles to the perimeter of the sleeve and not to the partition. Retaining angles should only sandwich the partition to prevent stress on the damper caused from partition expanding and contracting.
4. Angles shall be minimum of 1-1/2"x1-1/2"x16 GA on dampers up to 36"x50" and 1-1/2"x1-1/2"x14 GA on larger dampers. Fasten angles to the sleeve with 1/2" welds, 1/4" bolts, #10 sheet metal screws or 3/16" steel rivets maximum 6" on center and maximum 2" from each corner of the damper. The angles must be attached to all four sides of the sleeve with butt joints at each corner. A minimum of two attachments are required on each side. Retaining angles must completely cover the clearance space between the sleeve and the partition, plus overlap the partition a minimum of 1", including the corners.
5. Expansion clearance between the sleeve and the opening shall be a minimum of 1/8" per foot of width or height of the sleeve. The maximum size of the opening shall be 1/2" larger in either dimension of the allowable minimum size.
6. When reverse mounting angles, the size of the opening must be increased to maintain the specified expansion clearance between the angle/fasteners and the opening.
7. Connecting ducts shall terminate at the damper sleeve. Duct connections to the sleeve will be either breakaway or rigid types. **Refer to "Breakaway Connections" for more information.**
8. All connections not listed as breakaway type shall be considered rigid. For rigid type duct connections, the sleeve shall be minimum of 16 GA on dampers up to 36"x24" or 24" diameter, and 14 GA on larger dampers.
9. Suitable access must be provided for damper inspection and servicing. When it is not possible to achieve sufficient size access, it will be necessary to install a removable section of duct.
10. UL approved caulking, such as Dow Corning RTV732 or GE 108, is allowed between the mounting angles and the damper sleeve or partition construction. But caulking is not allowed between the damper sleeve and inside of the partition opening.
11. Dampers shall be maintained in intervals as defined in NFPA 90A unless local codes require more frequent or extensive maintenance.