

WARD INSTALLATION

1.5 Hour Fire Damper Installation Instructions FOR USE IN 2 HOUR RATED PARTITIONS OR LESS

75

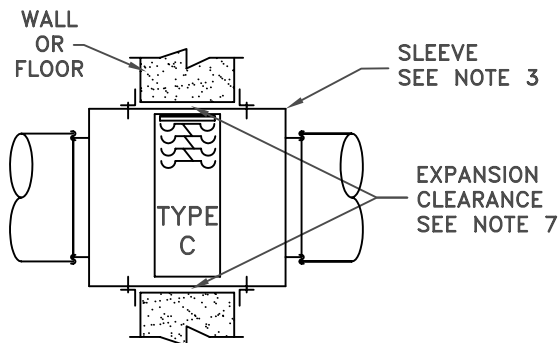
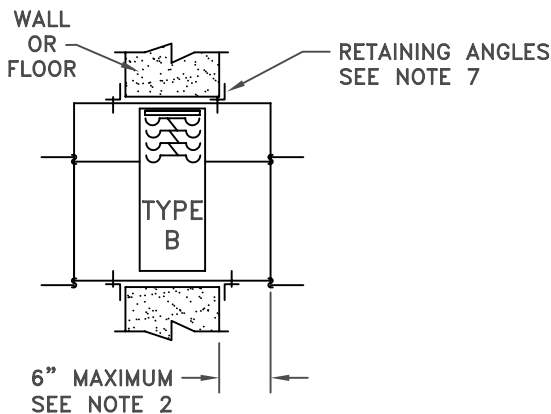
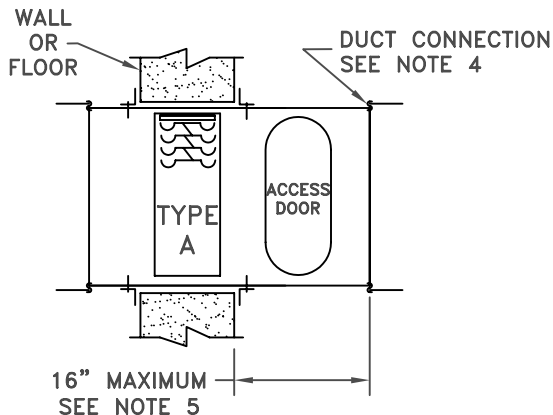

1. Installation shall be in accordance with the appropriate requirements of the National Fire Protection Association Bulletin NFPA 90A latest edition.
2. Vertical mounting shown, horizontal mounting similar.
3. Sleeve gauge shall not be less than the gauge of the duct to which it is attached. Gauges shall conform to SMACNA or ASHRAE duct standards. Damper sleeves of up to 36" wide by 24" high or 24" in diameter shall not be less than 16 gauge, with larger dimension sleeves not less than 14 gauge.
4. If the sleeve gauge is less than noted above, one of the following duct-sleeve connections shall be used: plain s slip, hemmed s slip, standing s slip, standing s slip (alternate), standing s slip (angle reinforce), standing s slip (bar reinforced), inside slip or double s slip. **Refer to "Breakaway Connections" for more information.**
5. Sleeves shall extend a minimum of 3" and a maximum of 6" on either side of the partition except when a factory installed access door and sleeve combination is used, in which case the extension of the access door side of the partition shall be a maximum of 16".
6. Damper shall be secured to sleeve at a maximum of 6" on center and 2" maximum from each corner of the damper with 1/2" welds, 1/4" bolts, 3/16" steel rivots or #10 sheet metal screws. Use a minimum of four attachments per side (two on each side of the blade channel) or 16 per damper are required. Fasteners must not enter the blade channel or interfere with damper operation. Dampers without attachment flanges must be welded to the sleeve.
7. Fire damper and sleeve assemblies must be installed using retaining angles on each side of the partition. Mount the angles to the perimeter of the sleeve and not to the partition. Retaining angles should only sandwich the partition, allowing for the minimum expansion clearance, to prevent stress on the damper caused from partition expanding and contracting. **Refer to "Sleeve Installation" for more information.**
8. In multiple damper assemblies, units shall be fastened together using #14 x 3/4" sheet metal screws with spacing described above.
9. For dampers behind grilles, attach grille to the sleeve flange with 1/4" rivets, #8 sheet metal screws or #8 bolts. Fasteners shall be plated steel or stainless steel, minimum two per side. Under no circumstance should the fastener penetrate the partition.

IMPORTANT

- Do not cast damper in place.
- Do not fasten retaining angles for damper directly to partition.
- Do not install damper out of square or out of flat.
- Cycle damper after install to ensure free movement.