

# WARD INSTALLATION

## Rectangular CRD Installation Instructions

FOR USE IN 3 HOUR PARTITIONS OR LESS WITH NON-DUCTED SUPPLY OR RETURN

50

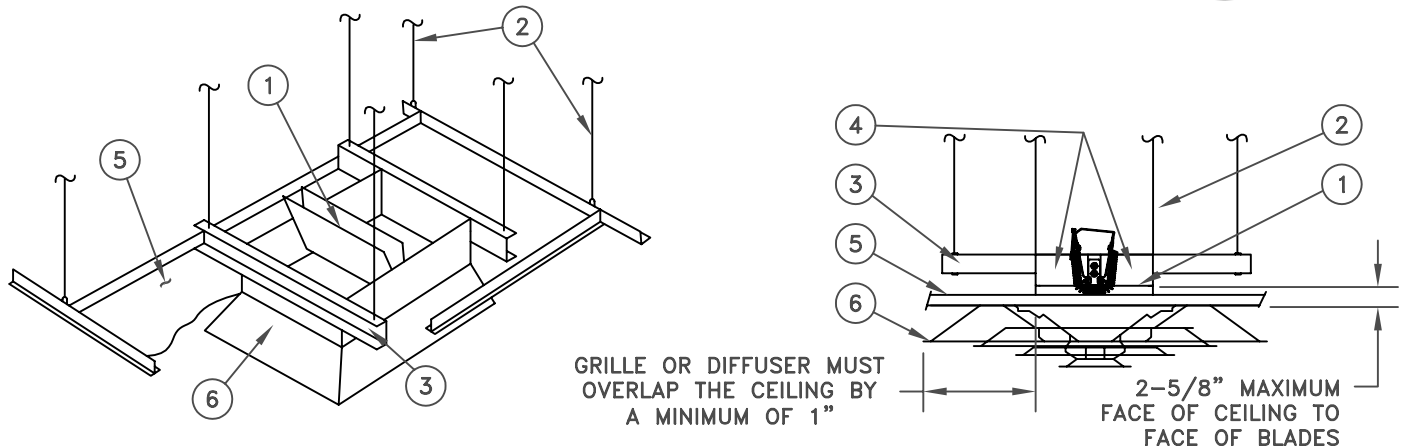

### ITEM DESCRIPTION

1. MODEL 50 CEILING RADIATION DAMPER
2. 12 GAUGE STEEL HANGER WIRES
3. COLD ROLLED STEEL SUPPORT CHANNELS (1-1/2" x 1/2" x 16 GA MINIMUM)\*
4. MOUNTING FASTENERS (3/16" x 1/2" BOLTS, #8 x 1/2" SHEET METAL SCREWS, 3/16" RIVETS, OR SPOT WELDS)\*
5. ACOUSTICAL PANEL, ACOUSTICAL TILE OR GYPSUM WALLBOARD CEILING (UL CLASSIFIED)
6. MOUNTED STEEL GRILLE OR DIFFUSER

\*FOR OPTIONAL METHOD

## INSTALLATION INSTRUCTIONS:

1. Before installing a model 50LP damper, open blades and hook fusible link over the link plates on each blade and bend down the catch to secure link in position. With the 50EA damper, flex the spring wire and secure the link.
2. Support the damper with a minimum of four hanger wires directly supported from structural members of the floor or roof in a vertical orientation, not diagonal. If the hanger wire cannot be install vertically, channels shall be used as required to ensure that the grid and damper are supported by vertical hanger wires.  
\*Optional: Support the damper with two support channels. Using one of the specified fasteners, secure the channel to the damper at a maximum of 6" on center and a minimum of three locations per side, ensuring that the fastener does not interfere with the damper operation. Use hanger wires to support each end of the channel, directly from structural members of the floor or roof in a vertical orientation, not diagonal. If the hanger wire cannot be install vertically, channels shall be used as required to ensure that the grid and damper are supported by hanger wires in a vertical orientation, not diagonal.
3. Duct outlets in the lay-in ceilings should be field located in an acoustical ceiling panel or tile. Where it is necessary to cut a runner or cross tee, each end shall be supported by a vertical hanger wire. A 1/2" clearance shall be maintained between the duct outlet and each cut end of a main runner or cross tee. The duct outlet shall be located so that no more than one main runner or cross tee is cut when penetrating the ceiling membrane.
4. Steel grille or diffuser to be attached to the ceiling damper using #8 x 1/2" sheet metal screws, 3/16" rivets, or 1/4" tack welds at a maximum of 6" on center and a minimum of three locations.
5. The flange on the grille or diffuser at the ceiling membrane level shall provide a minimum of 1" support for the ceiling panels. The clearance between each side of the ceiling damper and lay-in panel shall be a maximum of 1/8".