



Expansion Joint Covers

Technical Product Information

Curb Flange Installation Instructions

READ COMPLETE INSTRUCTIONS CAREFULLY BEFORE STARTING

STEP 1

Verify all necessary materials are on hand

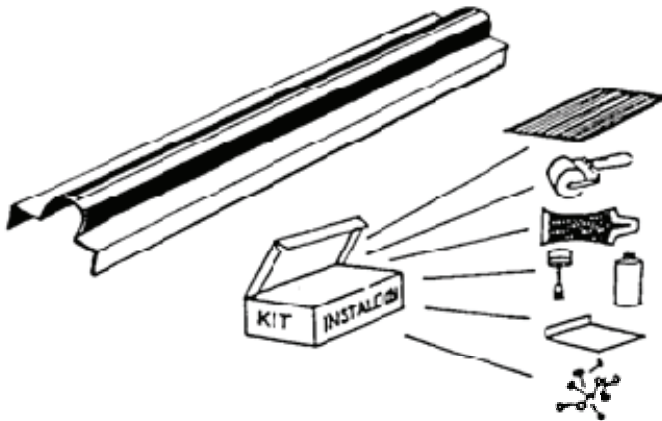

STEP 2

Install all Crossovers, Tees, and Corners first
Trim all flanges to leave 1/2" space between each joint. **BUTT BELLOWS**. Hold all mastic or adhesives back at all joints. Then install straight runs with the same space in flanges and the same butting of bellows



CURB TO CURB INSTALLATIONS

Bellow and curb sizes

- 4" Bellow = 6" max.
- 5" Bellow = 7" max.
- 6" Bellow = 8" max.
- 8" Bellow = 9" max.
- 10" Bellow = 10" max.
- 12" Bellow = 12" max.

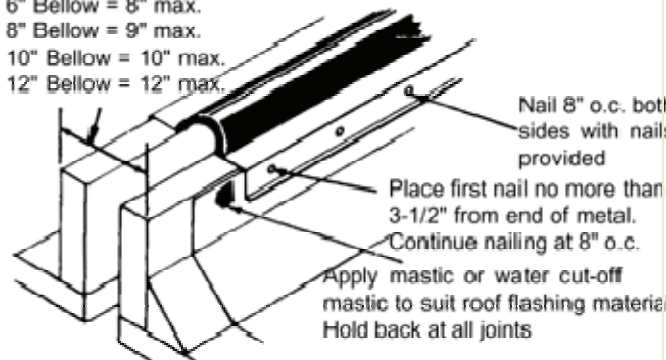

CURB TO WALL INSTALLATIONS

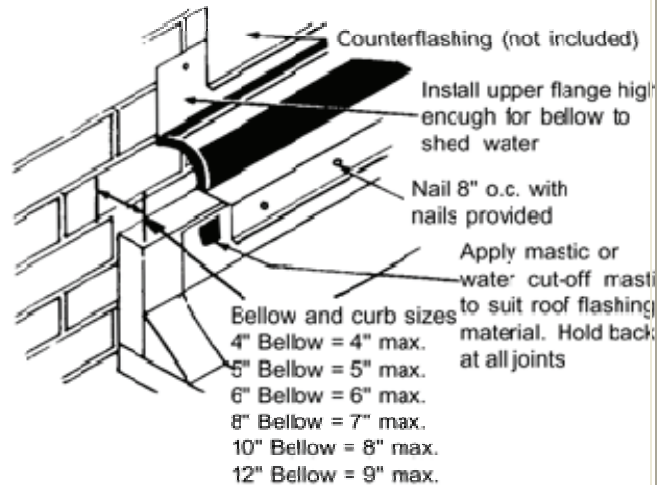

GRAVEL STOP & GUTTER TERMINATIONS

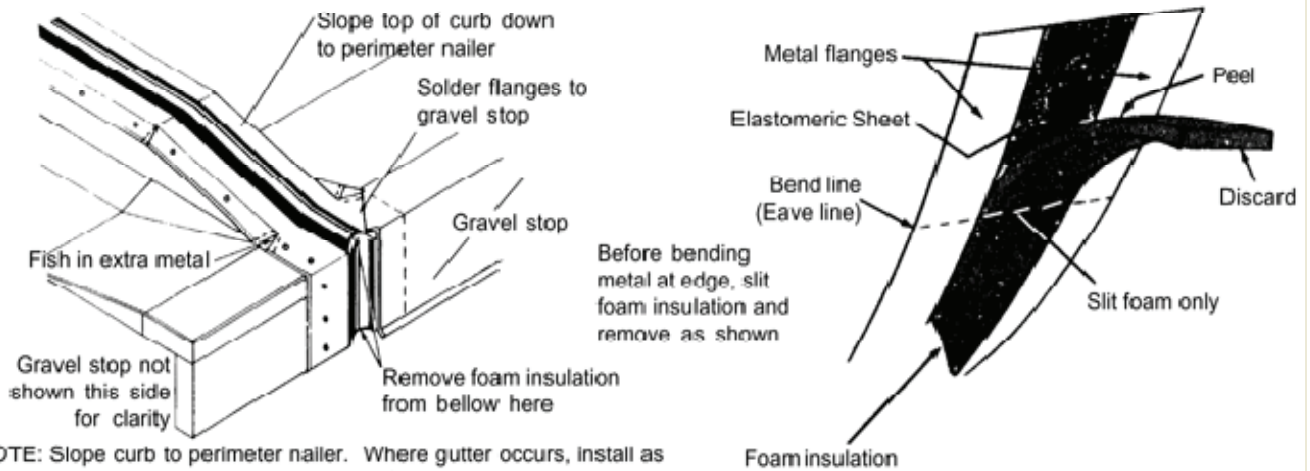

NOTE: Slope curb to perimeter nailer. Where gutter occurs, install as shown, except lap expansion joint cover OVER gravel stop into gutter

COLD WEATHER CAUTION:

For cold weather applications, make certain splice covers are warm and pliable before starting.

STEP 1

Make certain that all surfaces in area of joint are clean and dry. If necessary, clean metal flanges 4" on each side of joint with detergent or mild solvent to remove any oily film before proceeding. Use only the materials supplied with expansion joint covers for splicing.

Read directions on splicing primer can before starting. Brush splicing primer on bellows and both metal flanges, out 4" on each side butt joint. Use only enough to cover 1 to 1-1/2 mils dry thickness. Make certain joint has been covered with primer- especially metal flanges.

When primer is first applied, it will have a glossy appearance. Do not proceed to Step 2 until primer has dried to a dull appearance. 15 minutes is required for drying, unless an excessive amount has been applied. Do not leave primed joint exposed more than 1 hour before proceeding to Step 2.

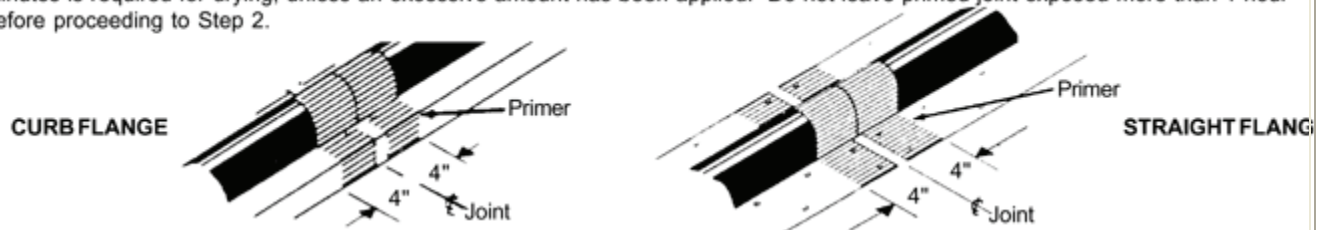

STEP 2

Peel the release paper halfway from one end of the self-sealing splice cover and crease (see Detail A).

Center the splice cover over butt joint with peeled side and crease in release paper down and centered over bellows (see Detail B). Allow cover to roll into place naturally and start pressing exposed side of cover onto the bellows with wood roller provided, holding end up. Work roller toward edges to remove all air bubbles. If air bubbles occur, pull cover back and roll out again before proceeding. Use metal tool provided to force cover tightly into junction of bellows and metal flanges (see Detail C). Do not stretch cover. Hold tool in place as cover is rolled over metal flange (see Detail D).

Peel release paper from remaining half of cover and install on second side of bellows as described and illustrated above.

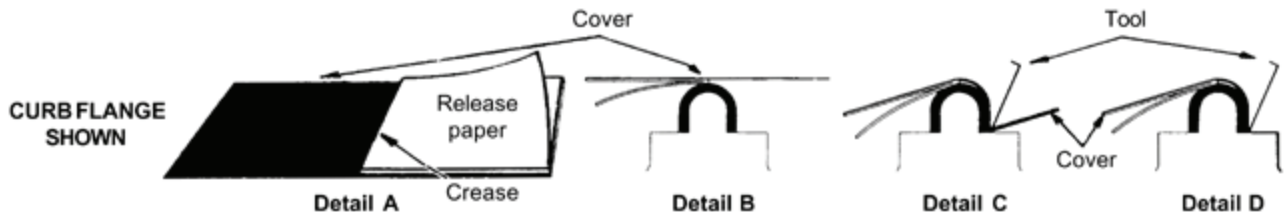

STEP 3

To complete the splice cover installation, apply a bead of caulking starting at the edge of the splice cover and extending out about 1" along the crimp at each of the four places where the splice cover crosses the crimp. Force as much caulking as necessary into the crimp to insure a tight seal.

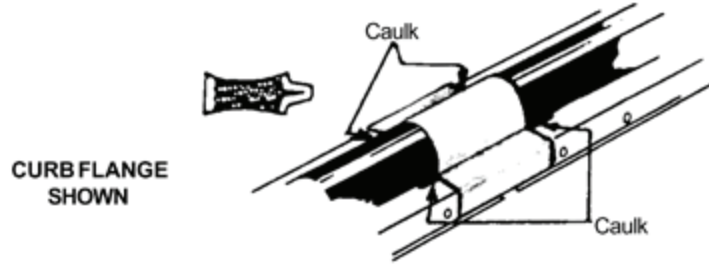

[CAD Page](#)

[Main Page](#)

PORTALS PLUS 815 Kimberly Drive, Carol Stream, IL 60188

TEL: (800) 624-8642 FAX: (866) 466-9335

All information is subject to change without notice. Dimensions and specifications shown are within manufacturing tolerances.
© Copyright Commercial Products Group of Hart & Cooley, Inc., January, 2008. All Rights Reserved.